



BCA 9S Plus

Product data

Digital Mobile C-Arm

ELECTRICAL CHARACTERISTICS	• Voltage	230 Vac \pm 10% monophase standard 105 / 115 / 125 / 220 / 240 Vac \pm 10% monophase on request
	• Frequency	50 Hz standard 60 Hz on request
	• Absorbed current on Stationary Anode Unit	4.5 A @ 230 Vac and 7.5 A @ 115 Vac in fluoro mode 20 A @ 230 Vac and 28 A @ 115 Vac in radiography mode
	• Line compensation	Automatic
	• Line resistance	< 0.4 Ω (supply at 230V) < 0.2 Ω (supply at 115V)
	• Standard mains plug	16 A (for supply at 230 Vac)
RADIOLOGICAL DATA	• Generator power in DC current	Max 3.5 kW (100 Kv, 35 mA, 100 ms)
	• High frequency inverter	40 kHz
	• Max. Ripple	<2% @ 100 kV
	• Max high voltage (radiography and fluoroscopy)	110 kVp
	• Max current in continuous fluoroscopy	8 mA
	• Max current in fluoroscopy "Boost"	10 mA
	• Max current in radiography	35 mA @ 230 V 18 mA @ 115 V
	• Max mAs in radiology	125 mAs @ 230 V 90 mAs @ 115 V
	• Exposure Time in radiography	0.03 \pm 5 sec
MONOBLOC	• Anode	Stationary
	• Anode inclination	12°
	• Focal Spot size according to IEC 336	0.6 mm small focus 1.5 mm large focus
	• Nominal anodic power	800 W small focus 4000 W large focus
	• Anode Heat storage capacity	40 kJ (54 kHU)
	• Max anode cooling speed	400 W, 19 kJ/min, 536 HU/sec, 25.4 kHU/min
	• Monobloc thermal capacity	500 kJ (670 kHU)
	• Max continuous thermal dissipation of the monobloc	75 W, 102 HU/sec, 6120 HU/min
	• Max. Fluoroscopy time	HU safety after 21' of fluoroscopy @ 110 kV, 5 mA (550 W)
	• Max fluoroscopy time @75W	75 kV - 1mA - Continuous fluoro (no limits)
	• Max fluoroscopy time @280W	80 kV - 3.5 mA - 44 Minutes
	• Max fluoroscopy time @525W	70 kV - 7.5 mA - 24 Minutes
	• Max fluoroscopy time @400W	100 kV - 4 mA - 29 Minutes
	• Max fluoroscopy time @550W	110 kV - 5 mA - 21 Minutes
• Total filtration	> 2.8 mm Al	





BCA 9S Plus

Product data **Digital Mobile C-Arm**

COLLIMATOR	• Type	Standard: Iris Optional: Iris + parallel shutters
	• Iris	Control by console with adjustable continuous opening until the max. allowed in function of the I.I. field selected. Iris automatic limitation on the I.I. field selected
	• Orientable shutters	Control by console for the opening/closing and clockwise/anti-clockwise rotation
IMAGE INTENSIFIER TUBE - 9/6/4"	• Field Number	3
	• Input nominal diameter	230 mm
	• Resolution (central)	48/56/64 lp/cm
	• Conversion factor	240 (cd · m ⁻² / mR · s ⁻¹)
	• Contrast Ratio	23:1 / 25:1 / 30:1
	• DQE @ 59.5 kV	65%
	• MTF	60% / 65% / 70% @ 10lp/cm 25% / 30% / 40% @ 20lp/cm
	• Integral Distortion	4% / 2% / 1%
• "All metal" Technology	Yes	
• Input screen "Hi-Res"	Yes	
• Antiscatter fixed grid	Ratio 8:1, 36 shutters/cm, focus 80 cm	
CCD CAMERA 0.5K X 0.5K	• Matrix	752 x 582 pixels
	• Technology	CCD sensor (470.000 pixels)
	• Video Standard	CCIR 625/50Hz interlaced with 752 x 582 pixels
	• Video Bandwidth	20 MHz ±3dB
	• Aspect ratio	4:3 Interlaced scanning
	• Signal – Noise Ratio	65 dB
	• Automatic video level compensation	YES
	• Dynamic contrast shading	YES



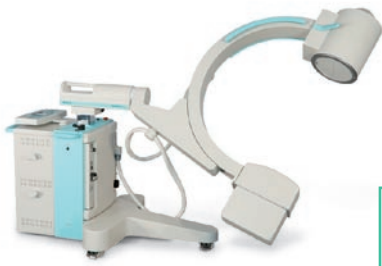

BCA 9S Plus

Product data **Digital Mobile C-Arm**

DIGITAL IMAGE SYSTEM WITH 0.5K x 0.5K CCD CAMERA

	LIH	1+330	1+2700	DIP 3000A
Image format	768 x 576 x 12bits 50Hz 256 grey level	768 x 576 x 12bits 50Hz 256 grey level	768 x 576 x 12bits 50Hz 256 grey level	576 x 576 x 12 bits
Image format working memory	N.A.	N.A.	N.A.	576 x 576 x 8 bits
Number of images	1 RAM	1+330 Non volatile	1+2700 Non volatile	1+192 buffer RAM
Number of images on Hard Disk	No	No	No	About 40.000
Programmable frame rate acquisition	NO	NO	NO	YES 1,3,6 fps
Number of monitors	1 (17")	2 (19")	2 (19")	2 (19")
Flicker Free	YES	YES	YES	YES
Recursive filter	YES	YES	YES	YES
Noise Reduction, OFF	2, 4, 8, 16	2, 4, 8, 16	2, 4, 8, 16	2, 4, 8,16
Smart filter, motion detector	No	No	No	YES (algorithms)
Editing data patient	No	YES	YES	YES
Digital Rotation of the image without X-ray emission	YES	YES	YES	YES
Vertical / Horizontal Image inversion	YES in combination with rotation	YES in combination with rotation	YES in combination with rotation	YES
Left / Right image inversion	NO	NO	NO	YES
Edge enhancement	YES Smooth, Normal Sharp	YES Smooth, Normal Sharp	YES Smooth, Normal Sharp	YES Smooth, Normal Sharp in real time
Grey scale inversion (negative / positive)	NO	YES	YES	YES
Cine loop review	NO	NO	NO	YES
Real Time Subtraction (DSA)	NO	NO	NO	YES
Max opac.	NO	NO	NO	YES
Road-mapping, capability for catheter placement	NO	NO	NO	YES
Shifting Pixel	NO	NO	NO	YES
Land marking	NO	NO	NO	YES
Overview	NO	NO	NO	YES, 4 / 16 images
Zoom	NO	NO	NO	YES by 2
Virtual Shutter	NO	NO	NO	YES
Contrast Enhancement	NO	NO	NO	YES with Logarithmic Exponential curve
Digital adjustment for contrast / brightness	NO	NO	NO	YES
Text editing	NO	NO	NO	YES
Overlay Note	NO	NO	NO	YES
Patients Directory	NO	NO	NO	YES
Infrared Remote Control	NO	NO	NO	Optional
Start-Stop DVD Recorder synchronization	NO	NO	NO	YES





BCA 9S Plus

Product data

Digital Mobile C- Arm

MONITORS COLOUR LCD DISPLAY

VERSION		17"	19"
	• Panel / type	17" TFT active matrix LCD, anti veiling glare, medical	19" TFT LCD anti-glare, medical
HARDWARE REQUIREMENTS	• Brightness and contrast controls	Dedicated knobs	Front pushbuttons
ELECTRICAL CHARACTERISTICS	• Standard power supply	18Vdc ±10%	110 to 240 Vac 60/50 Hz
DISPLAY CHARACTERICS	• Visibility angle	180°	178°
	• Contrast	1000:1	800:1
	• Resolution	1280 x 1024	1280 x 1024
	• Pixel pitch	0.264 x 0.264 mm	0.294 x 0.294 mm
	• Active Display area	---	376 mm (H) x 301 mm (V)
	• Gray scale	768 levels	256 x 3 = 768 levels / 16.7 Million colours
	• Max luminance	350 Cd/m ²	250 Cd/m ²
	• Aspect ratio	4:3	4:3
	• Response time	25 ms	15 ms
	• Video input	2 BNC connectors 75 Ohm	2 x BNC / 1 x D-Sub (VGA) / 1 x D-Sub (DVI-D)
ENVIROMENT AND RELIABILITY	• Operative	Temperature: from 0° to +40°C Humidity: 10% to 80% (non condensing)	Temperature: from 0° to +40°C Humidity: 20% to 80% (non condensing)
	• Temperature and storage	Temperature: from -20° to +60°C Humidity: 5% to 85% (non condensing)	Temperature: from -30° to +70°C Humidity: 10% to 80% (non condensing)





BCA 9S Plus

Product data **Digital Mobile C-Arm**

FUNCTIONALITY	DESCRIPTION	DATA
	User's interface	Membrane keyboard with alphanumeric touch-screen 5.7" LCD display for all the operative parameters and messages of eventual faulty conditions. Microprocessor management. User interface control could be rotate of 60°
	Selectable languages	Italian, English, French. German, Spanish (selection by set-up)
	I.I. field selection	Electronic zoom selection according to the number of I.I. fields with automatic limitation of the radiated field by the iris collimator.
	Thermal units	Check and visualization in real time of thermal units on the display according to the applied load. From 100% to 5% XR enabled. When there are 5 minutes of fluoroscopy (for the kV and mA values in use in that moment) to reach the 5% of the HUT, a particular audio-visible signal is activated. If more than 5 minutes are necessary to finish the exam, the fluoroscopy data have to be lowered. After reaching the 5% of the available HUT, the x-ray emission is stopped (*). In order to go on with the fluoroscopy, it is necessary to wait that the HUT have reached at least the 10%. (* In particular conditions it is possible to exclude this block and go on with the exam, under the direct responsibility of the qualified personnel or the doctor that uses the unit. In radiography it is not possible to control the x-ray emission any more when the 5% of the available HUT is reached.
	Fluoroscopy control	Multi-functioning foot switch: <ul style="list-style-type: none"> ➢ Pedal for continuous, pulsed and single shot (boost) fluoroscopy (functions selection by 3 different foot switches). ➢ Storage image on memory by foot switch without interrupting fluoroscopy
	On Stand	General magneto-thermic switch Key safety switch Emergency pushbutton Printer for Dose Area meter (optional)
	Monitor position	Directly on the stand with 1 monitor LCD orientable 17" NL series or: Monitor trolley with five wheels, two of them with stationary brake Lamp for x-ray emission warning Cable winding support Digital system with CCD 0.5K x 0.5 K Two monitors LCD 19" Alphanumeric keyboard Thermal Printer Sony or equivalent Medical Image Capture Device: MediCap USB150
	Safeties	Filament current Monobloc temperature Overload kV min / max. or fault H.V. Stored data check



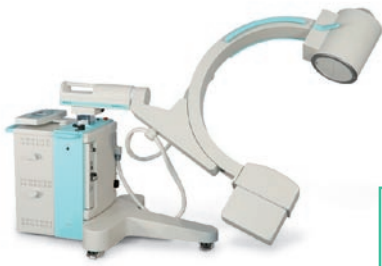

BCA 9S Plus

Product data

Digital Mobile C-Arm

OPERATIONAL MODES WITH 0.5K x 0.5K CCD CAMERA

OPERATIONAL MODES	MODE	CHARACTERISTIC	PERFORMANCES	
Continuous fluoroscopy	Dose control (kV - mA)	Automatic or manual		
	Focus	0.6 mm (CEI Tube)		
	kV variation range	40 - 110 kV		
	mA fluoro variation range	0.5 - 8 mA		
	kV - mA correlation	Standard: 40 kV / 0.5 mA, 80 kV / 7.6 mA, 110 kV / 8mA		
	Safety timer	Audible alarm resettable after 5' X-Ray X-Ray stop after 10' of continuous radiations according to IEC 60601-2-7 §29.1.104		
	Last image hold (LIH)			
Pulsed fluoroscopy	Range of exposure rate variation (Selectable by console)	From 2 image/sec to 1 image every 5 sec (2 image/1s; 1 image/1s; 1 image/2s; 1 image/3s; 1 image/5s)		
	XR flash time	Minimum time for better image		
	Other characteristics as per the continuous fluoroscopy			
One-shot Digital Radiography	mA variation range	1 - 10 mA		
	XR flash time	< 1 sec		
	Acquisition obtained by integrating 16 following readings			
	Automatic storage of the image on RAM or "nonvolatile memory", according to the memory type			
Other characteristics as for the continuous fluoroscopy				
mA 1/2 fluoroscopy	mA variation range	0.25 - 4 mA		
	kV - mA correlation	40 kV / 0.25 mA, 80 kV / 3.8 mA, 110 kV / 4 mA		
	Other characteristics as per the continuous fluoroscopy			
Anatomic APR selection, in fluoroscopy	APR 1 mA Low	Anatomic fine parts or paediatric use from 0.7 mA to 6.6 mA 40 kV / 0.7 mA 80 kV / 6.4 mA 110 kV / 6.6 mA		
	APR 2 mA Low	Lungs from 0.5 mA to 7 mA 40 kV / 0.5 mA 80 kV / 7 mA 110 kV / 6 mA		
	The curves cannot be modified by the operator			
Radiography	Working technique	2 points with kV and mAs setting		
	Focus	1.5 mm (TOSHIBA and CEI Tube)		
	kV variation range	40 - 110 kV		
	mA variation range	@ 230 Vac 25 mA fixed from 40 kV to 100kV 22 mA at 110kV	@ 115 Vac 18 mA fixed from 40 kV to 100kV 16 mA at 110kV	
	mAs variation range	@ 230 Vac 1 - 125 mAs from 40 to 100 kV 1 - 100 mAs from 101 to 110 kV in 42 steps, R 20 curve	@ 115 Vac 1 - 90 mAs from 40 to 100 kV 1 - 80 mAs from 101 to 110 kV	
	Times range	0.04 - 5 sec max V		
	Use coefficient (duty cycle)	Calculated as per the anode dissipation		
	APR anatomic selection in radiography	Description	Norm	Paediatric
APR 1 Head		77 kV 56 mAs	74 kV 45 mAs	80 kV 71 mAs
APR 2 Lungs		110 kV 11 mAs	107 kV 9 mAs	110 kV 14 mAs
APR 3 Pelvis		85 kV 22 mAs	82 kV 28 mAs	88 kV 18 mAs
Possibility to change and store with every APR: kV and mAs				



BMI
BIOMEDICAL INTERNATIONAL

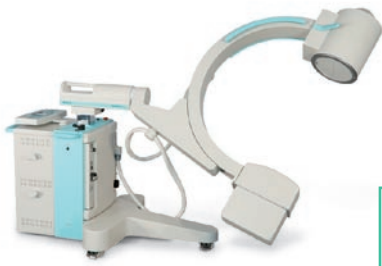

BCA 9S Plus

Product data **Digital Mobile C-Arm**

ENVIRONMENTAL CONDITIONS

Environmental condition in Normal Use	Temperature: from +10° to +40° Celsius Humidity: from 30% to 75% non condensing Pressure: from 700 to 1060 hPa
Environmental condition in Transport and Warehouse	Temperature: from -25° to +70° Celsius Humidity: from 10% to 90% not condensing Pressure: from 500 to 1060 hPa

WEIGHT AND DIMENSION

Description	Stand	Trolley, mod. "Low"	Trolley, mod. "Standard"	Trolley, mod. "High"
Weight	About 340 kg	About 67 kg	About 97 kg	About 150kg
(2) Depth in transport position	2000 mm	855 mm	855 mm	577 mm
(3) Height in transport position	1780 mm	1605 mm	1605 mm	1603 mm

Weights and dimensions can vary with different accessories

MECHANICAL CHARACTERISTICS

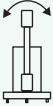
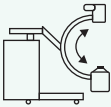
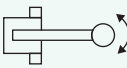
Vertical motion		500 mm motorized in 60 sec
Horizontal motion		210 mm
Panning motion		± 270°
Orbital rotation		123° (+90° ÷ -33°)
Pivotal rotation		± 12.5°
Free Space		770 mm
Depth C arm		690 mm
S.I.D.		988 mm
Focus Skin distance		218 mm
Movement		Manual. Steering rear wheels with manual control by the operator, swiveling front wheel. Stationary brake by hand
Stand Wheels diameter		Rear: Double wheels 125 x 40 mm Front: Double wheels 80 x 30 mm
Trolley Wheels diameter		Base Trolley 5 x 80 x 35 mm with brake High configuration Trolley 4 x 125 x 30 mm with brake
Protection against cables squashing		Semi-rigid rubber core-hitch on all the wheels of the stand.



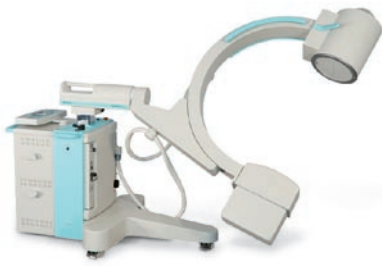

BCA 9S Plus

Product data **Digital Mobile C-Arm**

TECHNICAL DATA

STAND Dimension in mm

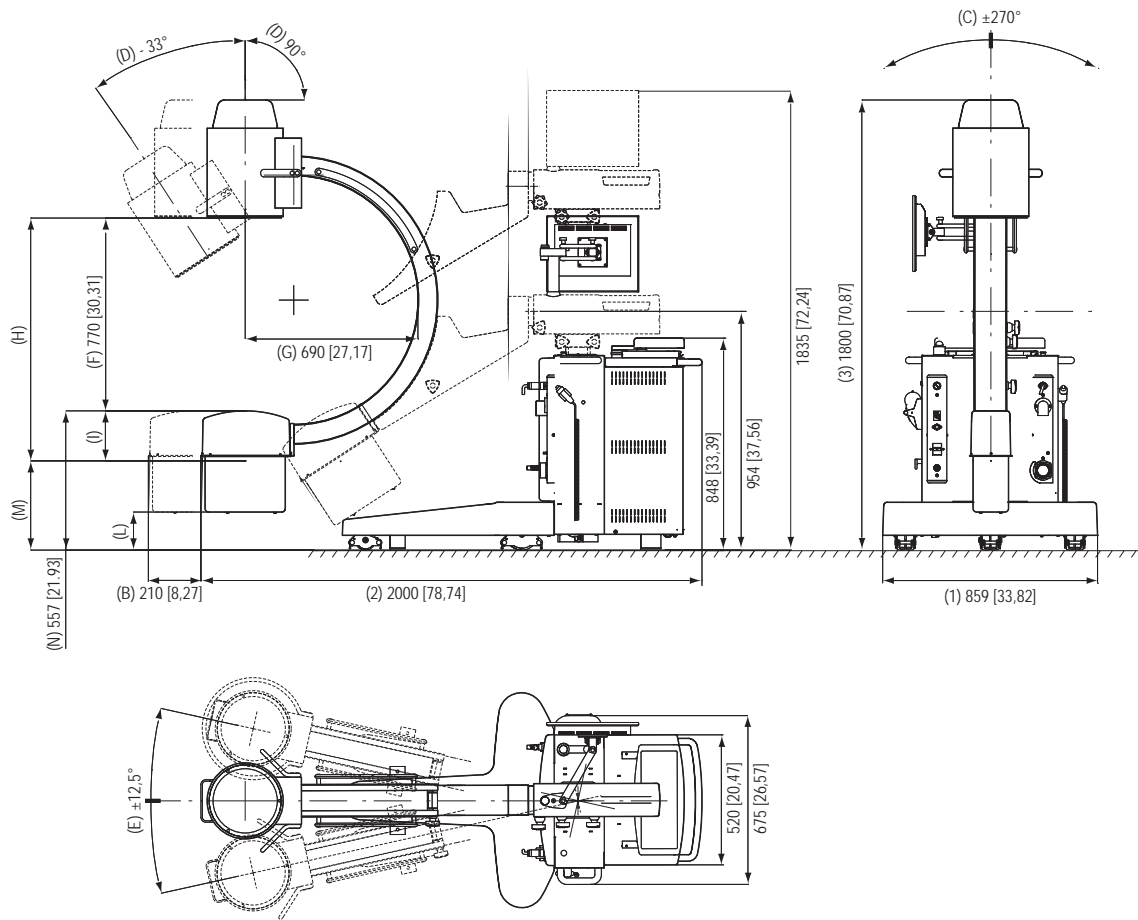

	FIXED ANODE
(H)	988 mm
(I)	218 mm
(L)	172 mm
(M)	339 mm



BMI
BIOMEDICAL INTERNATIONAL



BCA 9S Plus

Product data

Digital Mobile C-Arm

TECHNICAL DATA

TROLLEY MOD. "STANDARD"

Dimension in mm

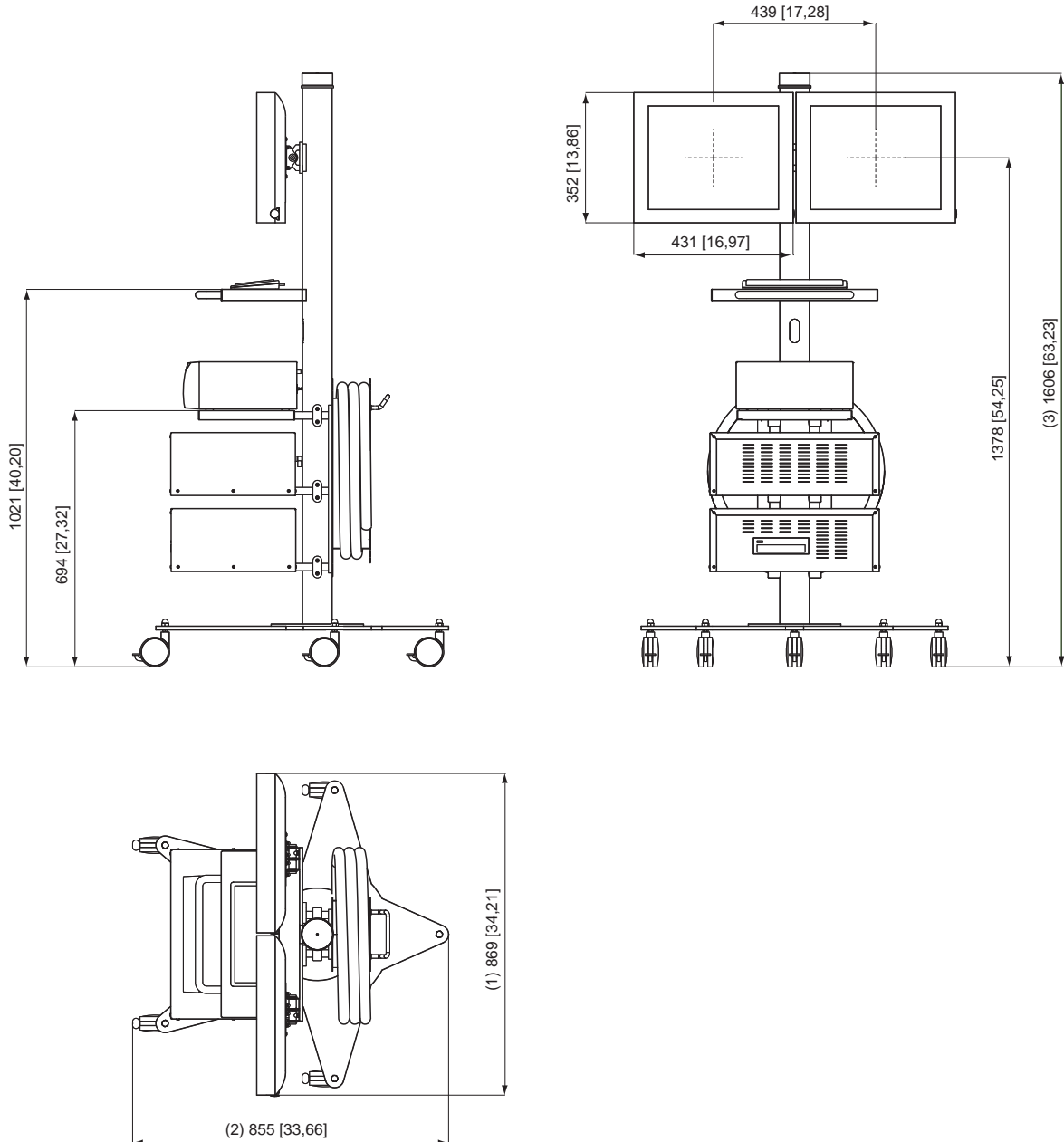

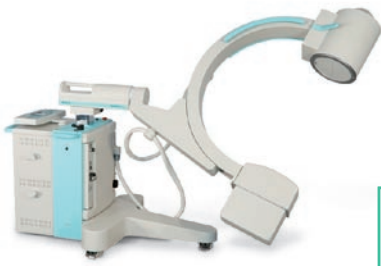

BCA 9S Plus

Product data

Digital Mobile C-Arm

TECHNICAL DATA

TROLLEY MOD. HIGH

Dimension in mm

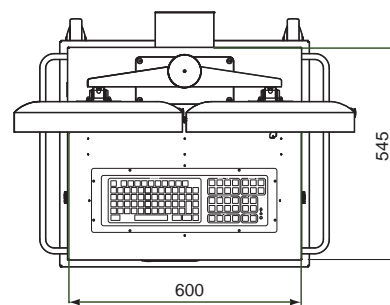
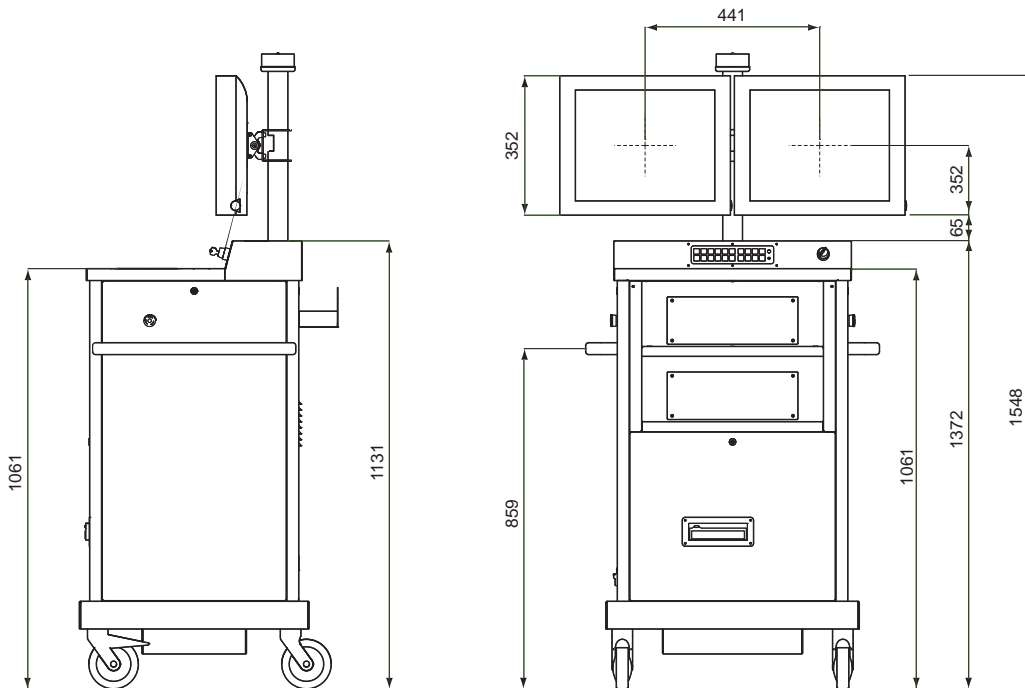

Note

Technical Specs can be subject to changes, in order to grant the highest quality levels, and so they can vary without notice obligation



BMI
BIOMEDICAL INTERNATIONAL

ESSE 3 Via Garibaldi 30
14022 Castelnuovo D.B. (AT)
tel +39 011 99 27 706
fax +39 011 99 27 506
e-mail esse3@tuttopmi.it
web : www.4ci.com

